

TITLE:

HV550FHB-N20 Product Specification

BEIJING BOE DISPLAY TECHNOLOGY

SPEC. NUMBER
S8-65-8A-101

PRODUCT GROUP
TFT LCD

REV
0

ISSUE DATE
2015.04.23

PAGE
1 of 24

Contents

No	ITEM	Page
	REVISIONS HISTORY	2
	CONTENTS	3
1	GENERAL DESCRIPTION	4
	1.1 Introduction	
	1.2 Features	
	1.3 Applications	
	1.4 General Specification	
2	ABSOLUTE MAXIMUM RATINGS	6
3	ELECTRICAL SPECIFICATIONS	7
	3.1 TFT LCD Open Cell	
4	INTERFACE CONNECTION	8
	4.1 Open Cell Input Signal & Power	
	4.2 LVDS Interface	
5	SIGNAL TIMING SPECIFICATIONS	11
	5.1 Timing Parameters	
	5.2 Signal Timing Waveform	
	5.3 Input Signals, Basic Display Colors & Cray Scale Of Colors	
	5.4 Power Sequence	
6	OPTICAL SPECIFICATIONS	15
7	MECHANICAL CHARACTERISTICS	17
8	RELIABILITY	18
9	PRODUCT SERIAL NUMBER	19
10	PACKING INFORMATION	20
11	HANDING & CAUTIONS	22
12	APPENDIX	23

1.0 GENERAL DESCRIPTION

1.1 Introduction

HV550FHB-N20 is a color active matrix TFT LCD open cell using amorphous silicon TFT's (Thin Film Transistors) as an active switching devices. This open cell has a 54.60 inch diagonally measured active area with FHD resolutions (1920 horizontal by 1080 vertical pixel array). Each pixel is divided into RED, GREEN, BLUE dots which are arranged in vertical stripe and this open cell can display 16.7M colors. The TFT-LCD panel used for this open cell is adapted for a low reflection and higher color type.

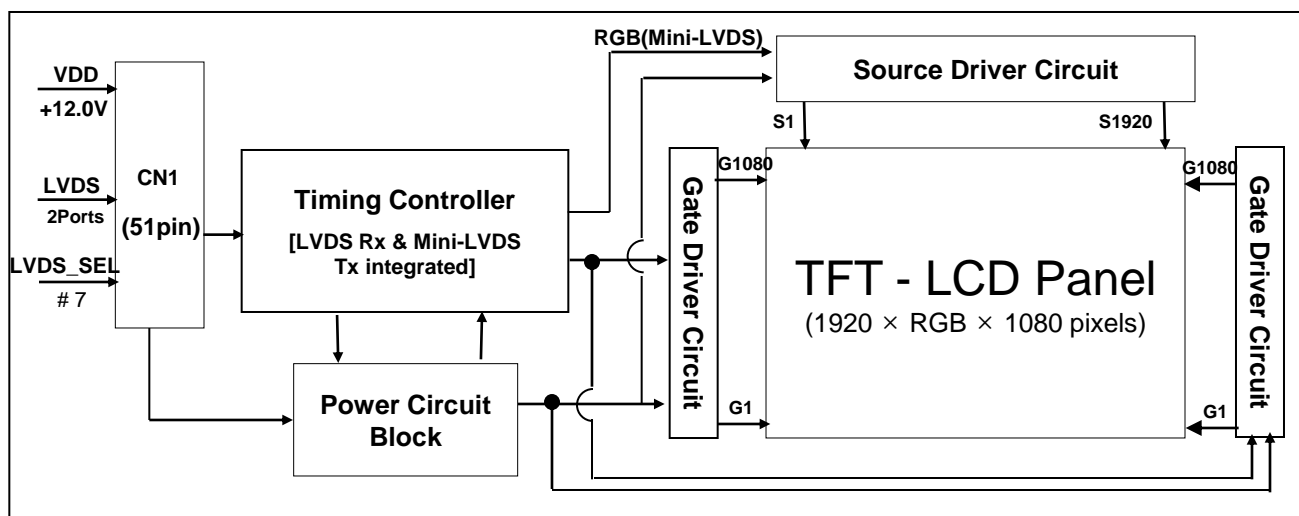

1.2 Features

- LVDS interface with 2 pixel / clock
- High-speed response
- Low color shift image quality
- 8-bit color depth, display 16.7M colors
- High luminance and contrast ratio, low reflection and wide viewing angle
- DE (Data Enable) only mode
- ADS technology is applied for high display quality
- RoHS compliant
- 0.5t Glass

1.3 Application

- Home Alone Multimedia TFT-LCD TV
- Display Terminals for Control System
- Full High Definition TV(FHD TV)
- AV application Products

1.4 General Specification

< Table 1. General Specifications >

Parameter	Specification	Unit	Remark
Active area	1209.6(H) × 680.4(V)	mm	
Outline Dimension	1224.8(H) × 699.3(V)	mm	
Number of pixels	1920(H) × 1080(V)	pixels	
Pixel pitch	630(H) × RGB × 630(V)	μm	
Pixel arrangement	Pixels RGB Vertical stripe		
Display colors	16.7M(8bits-true)	colors	
Display mode	Transmission mode, Normally Black		
Open Cell Transmittance	5.8 (Typ.)	%	At center point with BOE BLU
Weight	2.46	kg	With T-con Board
Power Consumption	5.5 (Typ.)	Watt	
Surface Treatment	Haze 1%,3H (Front Polarizer)		

2.0 ABSOLUTE MAXIMUM RATINGS

The followings are maximum values which, if exceed, may cause faulty operation or damage to the unit. The operational and non-operational maximum voltage and current values are listed in Table 2.

< Table 2. Open Cell Electrical Specifications >

[VSS=GND=0V]

Parameter	Symbol	Min.	Max.	Unit	Remark
Power Supply Voltage	VDD	VSS-0.3	13.5	V	Ta = 25 °C
Operating Temperature	T _{OP}	0	+50	°C	Note 1
	T _{SUR}	0	+60	°C	
Storage Temperature	T _{ST}	-20	+60	°C	
Operating Ambient Humidity	Hop	10	80	%RH	
Storage Humidity	Hst	10	80	%RH	

Note 1 : Temperature and relative humidity range are shown in the figure below.

Wet bulb temperature should be 39 °C max. and no condensation of water.

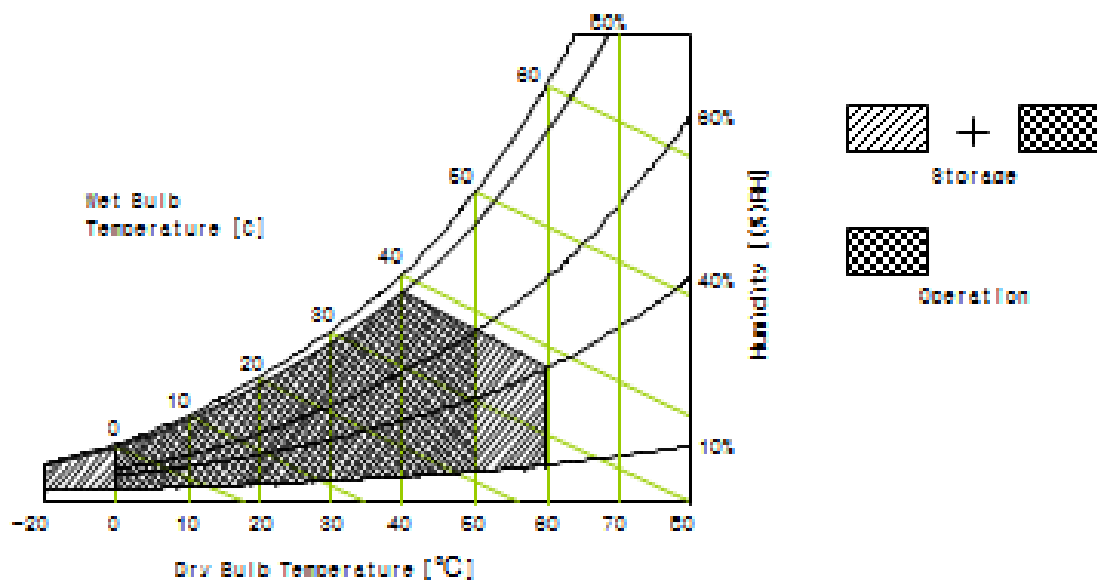

3.0 ELECTRICAL SPECIFICATIONS

3.1 TFT LCD Open Cell

< Table 3. Open Cell Electrical Specifications >

[Ta =25±2 °C]

Parameter		Symbol	Values			Unit	Remark
			Min	Typ	Max		
Power Supply Input Voltage		VDD	10.8	12	13.2	Vdc	
Power Supply Ripple Voltage		VRP			300	mV	
Power Supply Current		IDD	-	460	750	mA	Note 1
Power Consumption		PDD		5.5	8	Watt	
Rush current		IRUSH	-	4		A	Note 2
LVDS Interface	Differential Input High Threshold Voltage	VLVTH	+100		+300	mV	
	Differential Input Low Threshold Voltage	VLVTL	-300		-100	mV	
	Common Input Voltage	VLVC	1.0	1.2	1.4	V	
CMOS Interface	Input High Threshold Voltage	VIH	2.7	-	3.3	V	
	Input Low Threshold Voltage	VIL	0	-	0.6	V	

Note 1 : The supply voltage is measured and specified at the interface connector of LCM.

The current draw and power consumption specified is for VDD=12.0V,

Frame rate $f_v=60\text{Hz}$ and Clock frequency = 75.4MHz.

Note 2 :Test Pattern of power supply current& Flicker test Pattern

a) Typ : Color Test (L0/L255)

b) Max : Horizontal 1 Line (L0/L255)

c) Flicker test Pattern(L0/Green127)

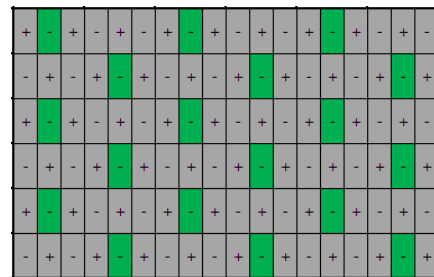
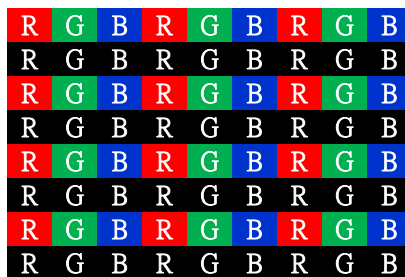
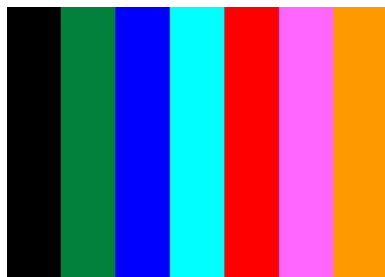

Note 2 : The duration of rush current is about 2ms and rising time of Power Input is 1ms(min)

4.0 INTERFACE CONNECTION

4.1 Open Cell Input Signal & Power

- Connector : IS050-C51B-C39-S (UJU)

< Table 4. Open Cell Input Connector Pin Configuration >

Pin No	Symbol	Description	Pin No	Symbol	Description
1	NC	No Connection	21	GND	Ground
2	SDA	I ² C Data	22	CH1[3]-	First pixel negative LVDS differential data input. Pair3
3	SCL	I ² C Clock	23	CH1[3]+	First pixel positive LVDS differential data input. Pair3
4	NC	Not Connected	24	CH1[4]-/NC	First pixel negative LVDS differential data input. Pair4
5	NC	Not Connected	25	CH1[4]+/NC	First pixel positive LVDS differential data input. Pair4
6	NC	Not Connected	26	NC	Not Connected
7	SELLVDS	High : JEIDA Low or Open: NS	27	NC	Not Connected
8	NC	Not Connected	28	CH2[0]-	Second pixel negative LVDS differential data input. Pair0
9	NC	Not Connected	29	CH2[0]+	Second pixel positive LVDS differential data input. Pair0
10	NC	Not Connected	30	CH2[1]-	Second pixel negative LVDS differential data input. Pair1
11	GND	Ground	31	CH2[1]+	Second pixel positive LVDS differential data input. Pair1
12	CH1[0]-	First pixel negative LVDS differential data input. Pair0	32	CH2[2]-	Second pixel negative LVDS differential data input. Pair2
13	CH1[0]+	First pixel positive LVDS differential data input. Pair0	33	CH2[2]+	Second pixel positive LVDS differential data input. Pair2
14	CH1[1]-	First pixel negative LVDS differential data input. Pair1	34	GND	Ground
15	CH1[1]+	First pixel positive LVDS differential data input. Pair1	35	CH2CLK-	First pixel negative LVDS clock
16	CH1[2]-	First pixel negative LVDS differential data input. Pair2	36	CH2CLK+	First pixel positive LVDS clock
17	CH1[2]+	First pixel positive LVDS differential data input. Pair2	37	GND	Ground
18	GND	Ground	38	CH2[3]-	Second pixel negative LVDS differential data input. Pair3
19	CH1CLK-	First pixel negative LVDS clock	39	CH2[3]+	Second pixel positive LVDS differential data input. Pair3
20	CH1CLK+	First pixel positive LVDS clock			

Pin No	Symbol	Description	Pin No	Symbol	Description
40	CH2[4]-/NC	Second pixel negative LVDS differential data input. Pair4	46	GND	Ground
41	CH2[4]+/NC	Second pixel positive LVDS differential data input. Pair4	47	NC	Not Connected
42	NC	Not Connected	48	VCC	Input Voltage
43	NC	Not Connected	49	VCC	Input Voltage
44	GND	Ground	50	VCC	Input Voltage
45	GND	Ground	51	VCC	Input Voltage

Notes : 1. NC(Not Connected) : This pins are only used for BOE internal operations.

2. Input Level of LVDS signal is based on the EIA 664 Standard.

3. LVDS_SEL : This pin is used for selecting LVDS signal data format.

If this Pin : High (3.3V) or Open (NC) → Normal NS LVDS format

Otherwise : Low (GND) → JEIDA LVDS format

Rear view of LCM

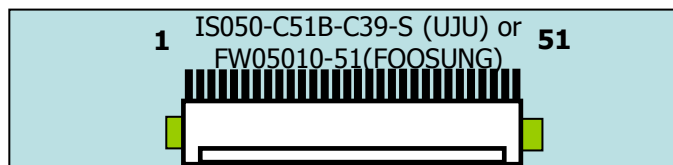

BIST Pattern

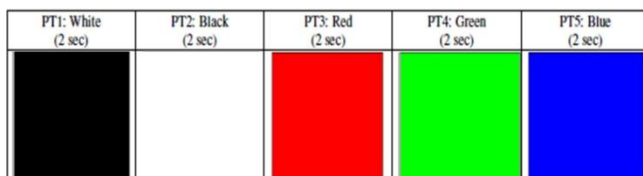

4.2 LVDS Interface

- LVDS Receiver : Timing Controller (LVDS Rx merged) / LVDS Data : Pixel Data

< Table 5. Open Cell Input Connector Pin Configuration >

Channel No.	Data No.	8-bit LVDS Type	
		NS	JEIDA
0	Bit-0	R0	R2
	Bit-1	R1	R3
	Bit-2	R2	R4
	Bit-3	R3	R5
	Bit-4	R4	R6
	Bit-5	R5	R7
	Bit-6	G0	G2
1	Bit-0	G1	G3
	Bit-1	G2	G4
	Bit-2	G3	G5
	Bit-3	G4	G6
	Bit-4	G5	G7
	Bit-5	B0	B2
	Bit-6	B1	B3
2	Bit-0	B2	B4
	Bit-1	B3	B5
	Bit-2	B4	B6
	Bit-3	B5	B7
	Bit-4	HS	HS
	Bit-5	VS	VS
	Bit-6	DE	DE
3	Bit-0	R6	R0
	Bit-1	R7	R1
	Bit-2	G6	G0
	Bit-3	G7	G1
	Bit-4	B6	B0
	Bit-5	B7	B1
	Bit-6	-	

4.3 LVDS Rx Interface Timing Parameter

The specification of the LVDS Rx interface timing parameter is shown in Table 6.

<Table 6. LVDS Rx Interface Timing Specification>

Item	Symbol	Min	Typ	Max	Unit	Remark
CLKIN Period	tRCIP	12.82	13.47	15.87	nsec	
Input Data 0	tRIP1	-0.42	0.0	+0.42	nsec	
Input Data 1	tRIP0	tRCIP/7-0.42	tRCIP/7	tRCIP/7+0.42	nsec	
Input Data 2	tRIP6	2 × tRCIP/7-0.42	2 × tRCIP/7	2 × tRCIP/7+0.42	nsec	
Input Data 3	tRIP5	3 × tRCIP/7-0.42	3 × tRCIP/7	3 × tRCIP/7+0.42	nsec	
Input Data 4	tRIP4	4 × tRCIP/7-0.42	4 × tRCIP/7	4 × tRCIP/7+0.42	nsec	
Input Data 5	tRIP3	5 × tRCIP/7-0.42	5 × tRCIP/7	5 × tRCIP/7+0.42	nsec	
Input Data 6	tRIP2	6 × tRCIP/7-0.42	6 × tRCIP/7	6 × tRCIP/7+0.42	nsec	

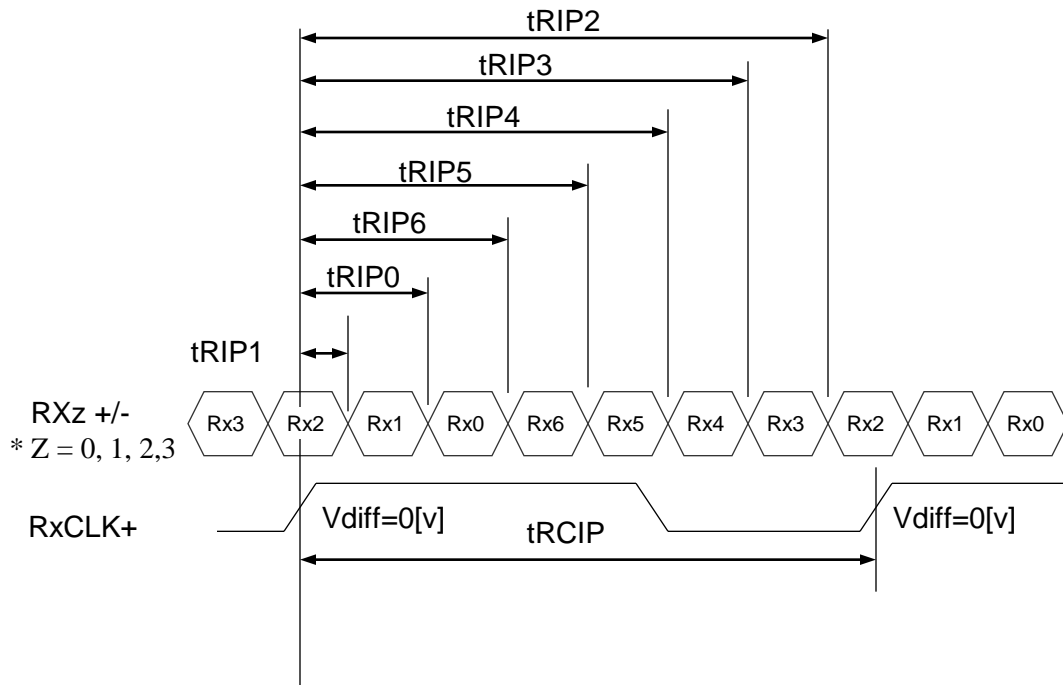

* Vdiff = (RXz+)-(RXz-),.....,(RXCLK+)-(RXCLK-)

5.0 SIGNAL TIMING SPECIFICATION

5.1 Timing Parameters (DE only mode)

< Table 6. Timing Table >

Item		Symbols		Min	Typ	Max	Unit
Clock	Frequency	1/Tc		63	74.25	78	MHz
	High Time	Tch		-	4/7Tc	-	
	Low Time	Tcl		-	4/7Tc	-	
Frame Period		Tv		1100 (1308)	1125 (1350)	1149 (1380)	lines
				57 (47)	60 (50)	63 (53)	Hz
Horizontal Active Display Term		Valid	t _{HV}	-	960	-	t _{CLK}
		Total	t _{HP}	1060	1100	1200	t _{CLK}
Vertical Active Display Term		Valid	t _{VV}	-	1080	-	t _{HP}
		Total	t _{VP}	1100	1125	1149	t _{HP}

Notes: This product is DE only mode. The input of Hsync & Vsync signal does not have an effect on normal operation.

5.2 Signal Timing Waveform

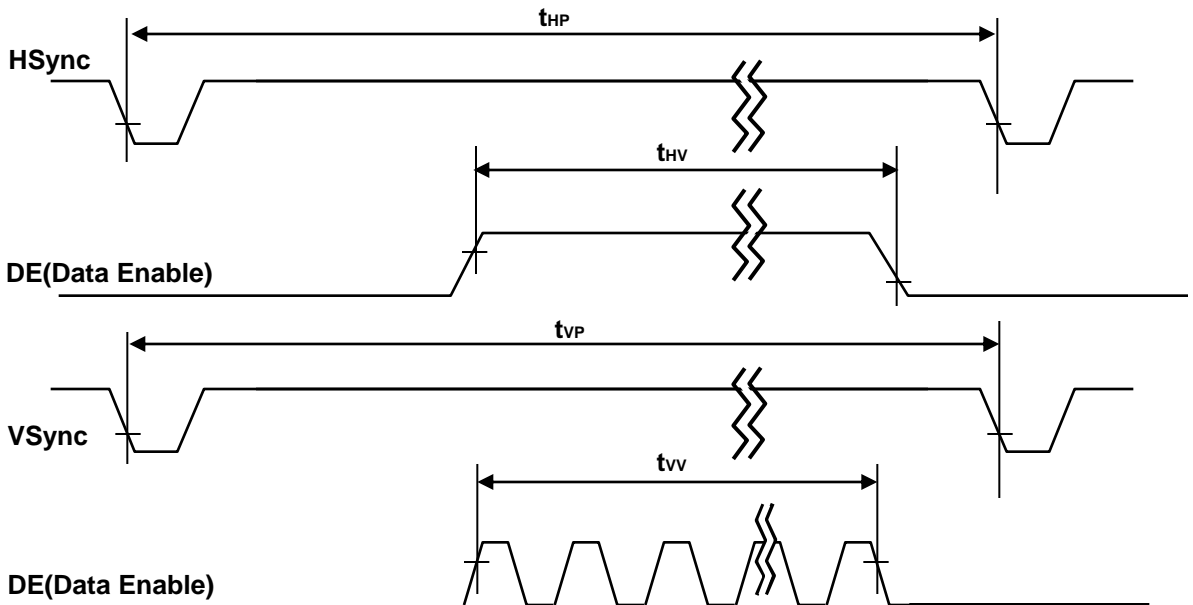
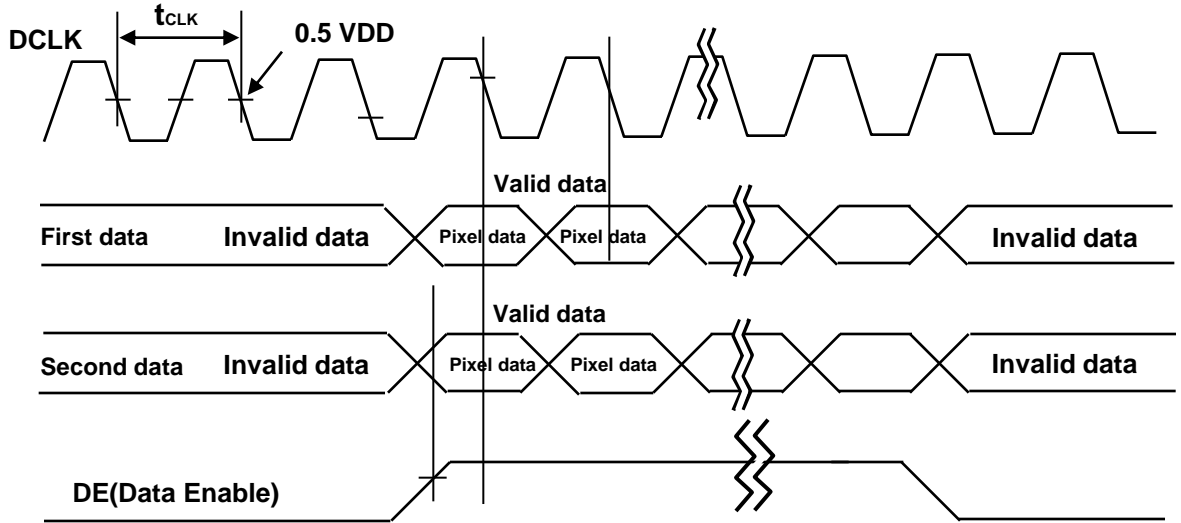

5.3 Input Signals, Basic Display Colors and Gray Scale of Colors

< Table 7. Input Signal and Display Color Table >

Color & Gray Scale		Input Data Signal																							
		Red Data								Green Data						Blue Data									
		R7	R6	R5	R4	R3	R2	R1	R0	G7	G6	G5	G4	G3	G2	G1	G0	B7	B6	B5	B4	B3	B2	B1	B0
Basic Colors	Black	0	0	0	0	0	0	0	0	0	0	0	0	0	0	0	0	0	0	0	0	0	0	0	0
	Blue	0	0	0	0	0	0	0	0	0	0	0	0	0	0	0	0	1	1	1	1	1	1	1	1
	Green	0	0	0	0	0	0	0	0	1	1	1	1	1	1	1	1	0	0	0	0	0	0	0	0
	Cyan	0	0	0	0	0	0	0	0	1	1	1	1	1	1	1	1	1	1	1	1	1	1	1	1
	Red	1	1	1	1	1	1	1	1	0	0	0	0	0	0	0	0	0	0	0	0	0	0	0	0
	Magenta	1	1	1	1	1	1	1	1	0	0	0	0	0	0	0	0	1	1	1	1	1	1	1	1
	Yellow	1	1	1	1	1	1	1	1	1	1	1	1	1	1	1	1	0	0	0	0	0	0	0	0
	White	1	1	1	1	1	1	1	1	1	1	1	1	1	1	1	1	1	1	1	1	1	1	1	1
Gray Scale of Red	Black	0	0	0	0	0	0	0	0	0	0	0	0	0	0	0	0	0	0	0	0	0	0	0	0
	△	0	0	0	0	0	0	0	1	0	0	0	0	0	0	0	0	0	0	0	0	0	0	0	0
	Darker	0	0	0	0	0	0	1	0	0	0	0	0	0	0	0	0	0	0	0	0	0	0	0	0
	△	↑								↑						↑									
	▽	↓								↓						↓									
	Brighter	1	1	1	1	1	1	0	1	0	0	0	0	0	0	0	0	0	0	0	0	0	0	0	0
	▽	1	1	1	1	1	1	1	0	0	0	0	0	0	0	0	0	0	0	0	0	0	0	0	0
	Red	1	1	1	1	1	1	1	1	0	0	0	0	0	0	0	0	0	0	0	0	0	0	0	0
Gray Scale of Green	Black	0	0	0	0	0	0	0	0	0	0	0	0	0	0	0	0	0	0	0	0	0	0	0	0
	△	0	0	0	0	0	0	0	0	0	0	0	0	0	0	0	1	0	0	0	0	0	0	0	0
	Darker	0	0	0	0	0	0	0	0	0	0	0	0	0	0	1	0	0	0	0	0	0	0	0	0
	△	↑								↑						↑									
	▽	↓								↓						↓									
	Brighter	0	0	0	0	0	0	0	0	1	1	1	1	1	1	0	1	0	0	0	0	0	0	0	0
	▽	0	0	0	0	0	0	0	0	1	1	1	1	1	1	1	0	0	0	0	0	0	0	0	0
	Green	0	0	0	0	0	0	0	0	1	1	1	1	1	1	1	1	0	0	0	0	0	0	0	0
Gray Scale of Blue	Black	0	0	0	0	0	0	0	0	0	0	0	0	0	0	0	0	0	0	0	0	0	0	0	0
	△	0	0	0	0	0	0	0	0	0	0	0	0	0	0	0	0	0	0	0	0	0	0	0	1
	Darker	0	0	0	0	0	0	0	0	0	0	0	0	0	0	0	0	0	0	0	0	0	0	1	0
	△	↑								↑						↑									
	▽	↓								↓						↓									
	Brighter	0	0	0	0	0	0	0	0	0	0	0	0	0	0	0	0	1	1	1	1	1	1	0	1
	▽	0	0	0	0	0	0	0	0	0	0	0	0	0	0	0	0	1	1	1	1	1	1	1	0
	Blue	0	0	0	0	0	0	0	0	0	0	0	0	0	0	0	0	1	1	1	1	1	1	1	1
Gray Scale of White	Black	0	0	0	0	0	0	0	0	0	0	0	0	0	0	0	0	0	0	0	0	0	0	0	0
	△	0	0	0	0	0	0	0	1	0	0	0	0	0	0	0	1	0	0	0	0	0	0	0	1
	Darker	0	0	0	0	0	0	1	0	0	0	0	0	0	0	1	0	0	0	0	0	0	0	1	0
	△	↑								↑						↑									
	▽	↓								↓						↓									
	Brighter	1	1	1	1	1	1	0	1	1	1	1	1	1	1	0	1	1	1	1	1	1	1	0	1
	▽	1	1	1	1	1	1	1	0	1	1	1	1	1	1	1	0	1	1	1	1	1	1	1	0
	White	1	1	1	1	1	1	1	1	1	1	1	1	1	1	1	1	1	1	1	1	1	1	1	1

5.4 Power Sequence

To prevent a latch-up or DC operation of the Open Cell, the power on/off sequence shall be as shown in below

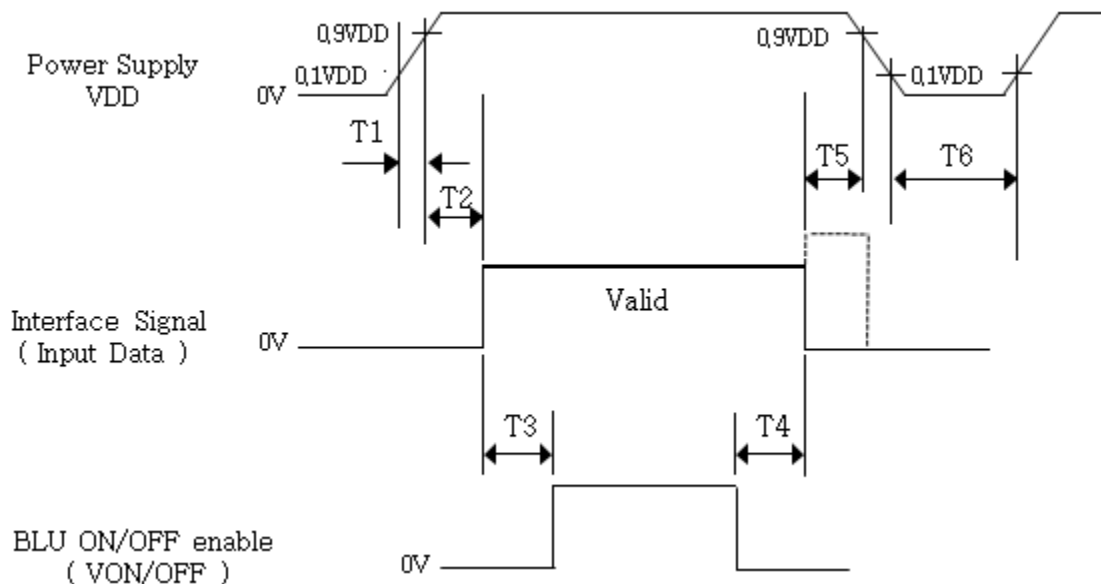

< Table 8. Sequence Table >

Parameter	Values			Units
	Min	Typ	Max	
T1	0.5	-	20	ms
T2	10	-	100	ms
T3	200	-	-	ms
T4	200	-	-	ms
T5	0	-	-	ms
T6	1	-	-	s

Notes: 1. Back Light must be turn on after power for logic and interface signal are valid.

2. Even though T1 is out of SPEC, it is still ok if the inrush current of VDD is below the limit.

6.0 OPTICAL SPECIFICATIONS

The test of optical specifications shall be measured in a dark room (ambient luminance \leq 1 lux and temperature $=25\pm 2^{\circ}\text{C}$) with the equipment of Luminance meter system (Goniometer system and PR730) and test unit shall be located at an approximate distance 50cm from the LCD surface at a viewing angle of θ and Φ equal to 0° . We refer to $\theta_{\Phi=0}$ ($=\theta_3$) as the 3 o'clock direction (the "right"), $\theta_{\Phi=90}$ ($=\theta_{12}$) as the 12 o'clock direction ("upward"), $\theta_{\Phi=180}$ ($=\theta_9$) as the 9 o'clock direction ("left") and $\theta_{\Phi=270}$ ($=\theta_6$) as the 6 o'clock direction ("bottom"). While scanning θ and/or Φ , the center of the measuring spot on the Display surface shall stay fixed. The measurement shall be executed after 30 minutes warm-up period. VDD shall be 12.0V \pm 10% at 25°C . Optimum viewing angle direction is 6 'clock.

< Table 9. Optical Table >

[VDD = 12.0V, Frame rate = 60Hz, Ta = $25\pm 2^{\circ}\text{C}$]

Parameter			Symbol	Condition	Min	Typ	Max	Unit	Remark
Viewing Angle	2D	Horizontal	Θ_3	CR > 10		89		Deg.	Note 1
			Θ_9			89		Deg.	
		Vertical	Θ_{12}			89		Deg.	
			Θ_6			89		Deg.	
Contrast ratio			CR		1000:1	1200:1	-		Note 2
Reproduction of color	White		W_x	$\Theta = 0^{\circ}$ (Center) Normal Viewing Angle	TYP. - 0.03	0.280	TYP. + 0.03		Note 3
			W_y			0.290			
	Red		R_x			0.644			
			R_y			0.334			
	Green		G_x			0.282			
			G_y			0.639			
	Blue		B_x			0.149			
			B_y			0.052			
Response Time	G to G		T_g		-	8	10	ms	Note 4
Gamma Scale					2.0	2.2	2.4		
Cell Transmittance						5.8		%	Note 5

Remark: The above-mentioned Optical Data are Based on BOE BLU

Note :

1. Viewing angle is the angle at which the contrast ratio is greater than 10. The viewing are determined for the horizontal or 3, 9 o'clock direction and the vertical or 6, 12 o'clock direction with respect to the optical axis which is normal to the LCD surface.
2. Contrast measurements shall be made at viewing angle of $\theta=0^\circ$ and at the center of the LCD surface. Luminance shall be measured with all pixels in the view field set first to white, then to the dark (black) state. (See Figure 1 shown in Appendix) Luminance Contrast Ratio (CR) is defined mathematically.

$$CR = \frac{\text{Luminance when displaying a white raster}}{\text{Luminance when displaying a black raster}}$$

3. The color chromaticity coordinates specified in Table 9 shall be calculated from the spectral data measured with all pixels first in red, green, blue and white. Measurements shall be made at the center of the panel. The BLU is used by BOE.
4. Response time T_g is the average time required for display transition by switching the input signal as below table and is based on Frame rate $f_V=60\text{Hz}$ to optimize. Each time in below table is defined as Figure 2 and shall be measured by switching the

Measured Response Time	Target																
	0	15	31	47	63	79	95	111	127	143	159	175	191	207	223	239	255
Start	0																
	15																
	31																
	47																
	63																
	79																
	95																
	111																
	127																
	143																
	159																
	175																
	191																
	207																
	223																
	239																
255																	

5. Definition of Transmittance (T%) :

Module is with white(L255) signal input

$$\text{Transmittance} = \frac{\text{Luminance of LCD Module}}{\text{Luminance of BLU}} \times 100 \%$$

7.0 MECHANICAL CHARACTERISTICS

7.1 Dimensional Requirements

Figure 4(located in Appendix) shows mechanical outlines for the model HV550FHB-N20. Other parameters are shown in Table 10.

< Table 10. Dimensional Parameters >

Parameter	Specification	Unit
Active area	1209.6 (H) × 680.4(V)	mm
Outline Dimension	1224.8(H) × 699.3(V)	mm
Pixel pitch	630 (H) × 630 (V)	mm
Number of pixels	1920(H) × 1080(V) (1 pixel = R + G + B dots)	pixels
Weight	2.46 (Typ.)	kg

7.2 Semi-Glare and Polarizer Hardness

The surface of the LCD has an Anti-glare coating to minimize reflection and a coating to Reduce scratching.

8.0 RELIABILITY TEST

The Reliability test items and its conditions are shown in below.

< Table 11. Reliability Test Parameters >

No	Test Items	Conditions
1	High temperature storage test	Ta = 60 °C, 240 hrs
2	Low temperature storage test	Ta = -20 °C, 240 hrs
3	High temperature & high humidity operation test	Ta = 50 °C, 80%RH, 240hrs
4	High temperature operation test	Ta = 50 °C, 240hrs
5	Low temperature operation test	Ta = 0 °C, 240hrs
6	Thermal shock	Ta = -20 °C ↔ 60 °C (0.5 hr), 100 cycle

This test condition is based on BOE module.

9.0 PRODCUT SERIAL NUMBER

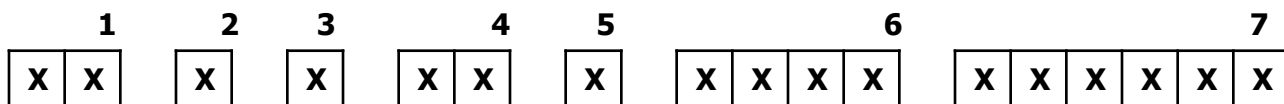

- 1. Control Number
- 2. Rank / Grade
- 3. Line Classification
- 4. Year (2011 : 11, 2012 : 12, ...)

- 5. Month (1,2,3, ... , 9, X, Y, Z)
- 6. Internal Use
- 7. Serial Number

10.0 PACKING INFORMATION

BOE provides the standard shipping container for customers, unless customer specifies their packing information. The standard packing method and Barcode information are shown in below.

10.1 Packing Order

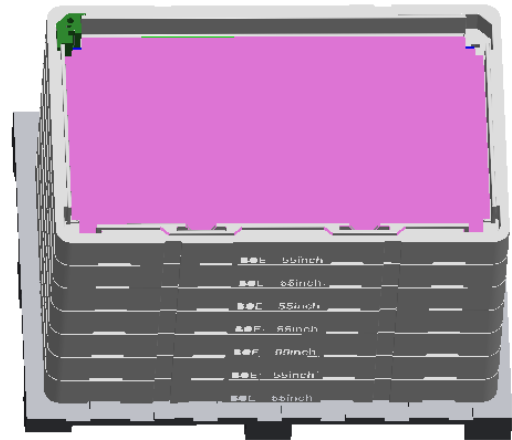
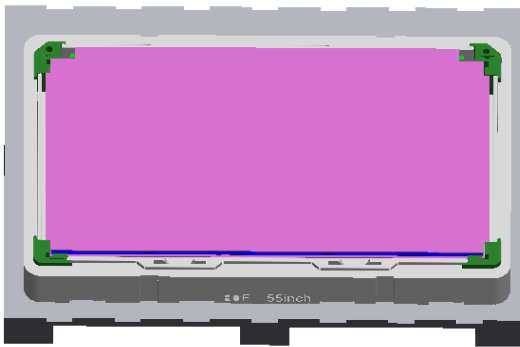

1 Box: 10 Panel +11 EPE Space+2 PP PAD +2 desiccant

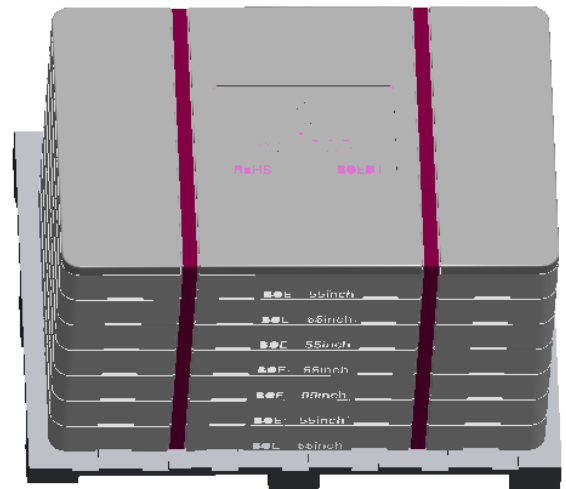
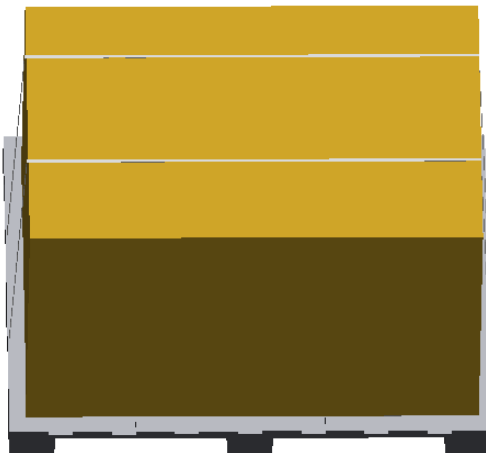

1 Pallet: 7 Box + 1Cover

10.2 Packing Note

- Box Dimension : 1383mmL×890mmW×132mmH
- Package Quantity in one Box : 10pcs

10.3 Box Label

- Label Size : 110 mm (L) × 55 mm (W)
- Contents

Model : HV550FHB-N20

Q`ty : 10 Open Cell in one box.

Serial No. : Box Serial No. See next page for detail description.

Date : Packing Date

FG Code : FG Code of Product

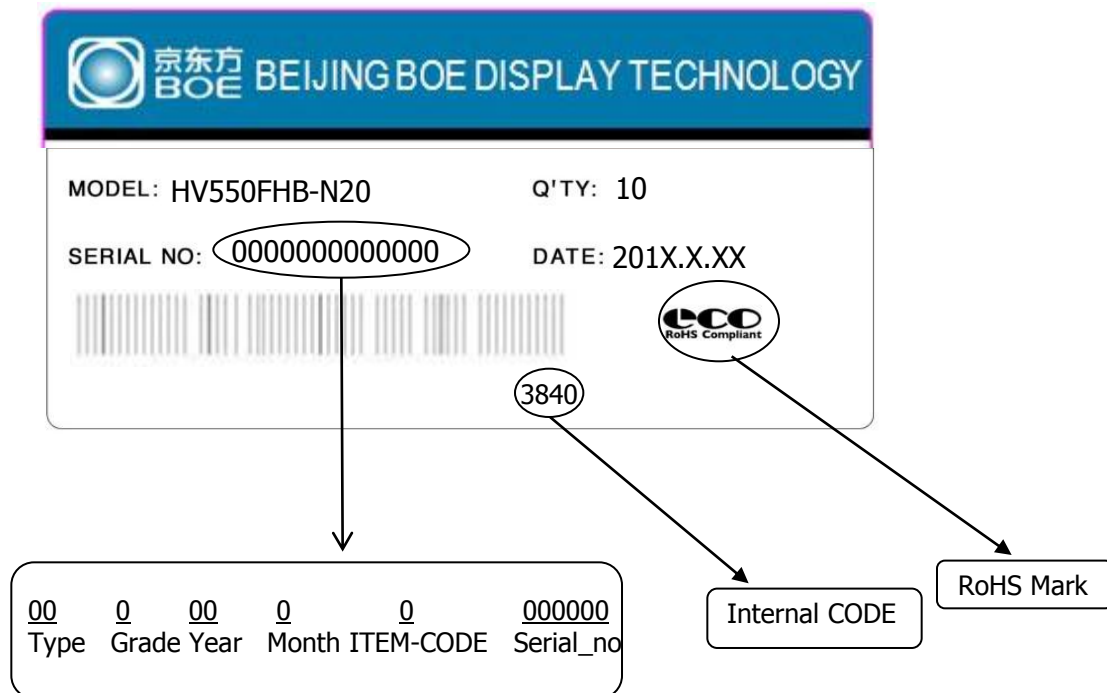

11.0 HANDLING & CAUTIONS

- (1) Cautions when taking out the Panel
 - Pick the pouch only, when taking out panel from a shipping package.
- (2) Cautions for handling the panel
 - As the electrostatic discharges may break the LCD panel, handle the LCD panel with care. Peel a protection sheet off from the LCD panel surface as slowly as possible.
 - As the LCD panel and back - light element are made from fragile glass material, impulse and pressure to the LCD panel should be avoided.
 - As the surface of the polarizer is very soft and easily scratched, use a soft dry cloth without chemicals for cleaning.
 - Do not pull the interface connector in or out while the LCD panel is operating.
 - Put the panel display side down on a flat horizontal plane.
 - Handle connectors and cables with care.
- (3) Cautions for the operation
 - When the panel is operating, do not lose CLK, ENAB signals. If any one of these signals is lost, the LCD panel would be damaged.
 - Obey the supply voltage sequence. If wrong sequence is applied, the panel would be damaged.
- (4) Cautions for the atmosphere
 - Dew drop atmosphere should be avoided.
 - Do not store and/or operate the LCD panel in a high temperature and/or humidity atmosphere. Storage in an electro-conductive polymer packing pouch and under relatively low temperature atmosphere is recommended.
- (5) Cautions for the panel characteristics
 - Do not apply fixed pattern data signal to the LCD panel at product aging.
 - Applying fixed pattern for a long time may cause image sticking.
- (6) Other cautions
 - Do not disassemble and/or re-assemble LCD panel.
 - Do not re-adjust variable resistor or switch etc.
 - When returning the panel for repair or etc., Please pack the panel not to be broken. We recommend to use the original shipping packages.

12.0 APPENDIX

< Figure 1. Measurement Set Up >

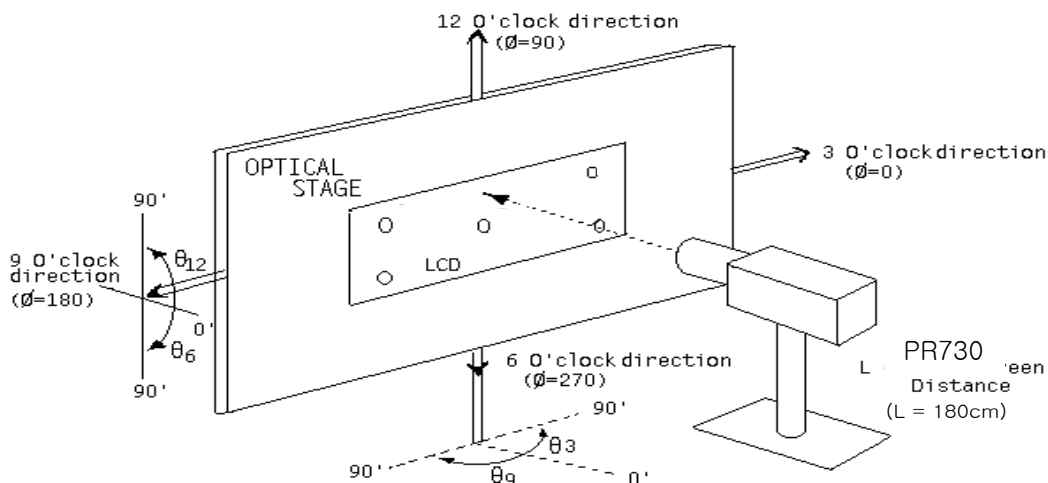

< Figure 2. Response Time Testing >

Any level of gray (Bright)

Any level of gray (Dark)

Any level of gray (Bright)

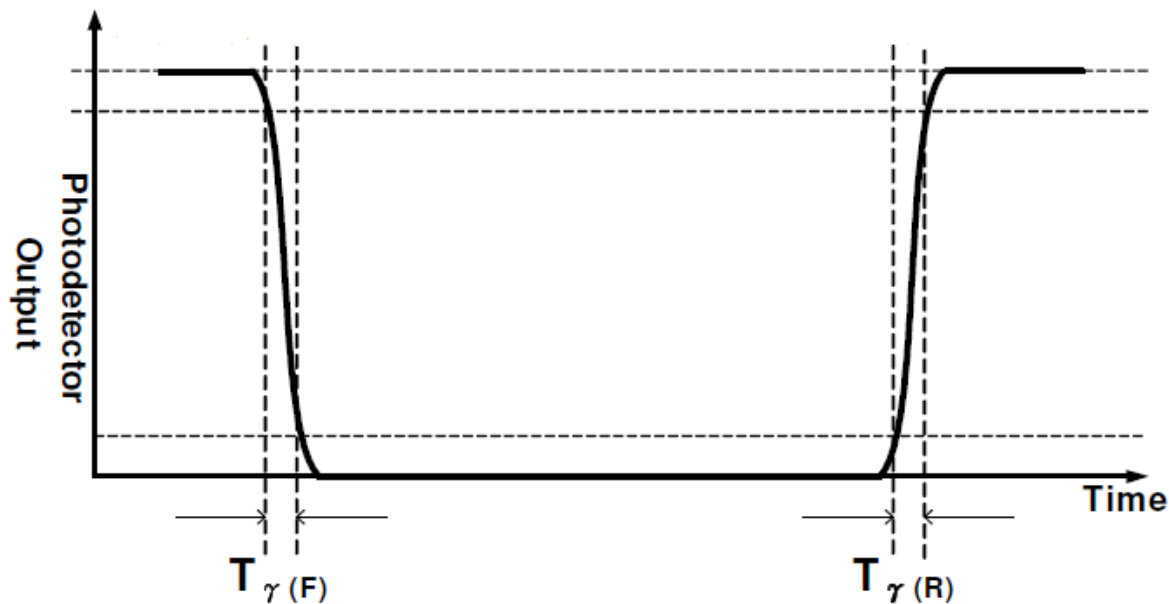

< Figure 4. TFT-LCD Open Cell Outline Dimensions (Front View) >

