

REV.	ECN.NO.	MODIFY.CONTENT	DATE
A		NEW	2011/10/31

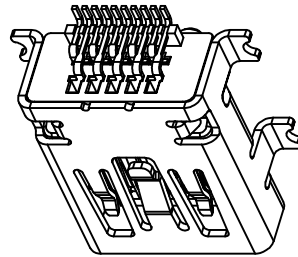
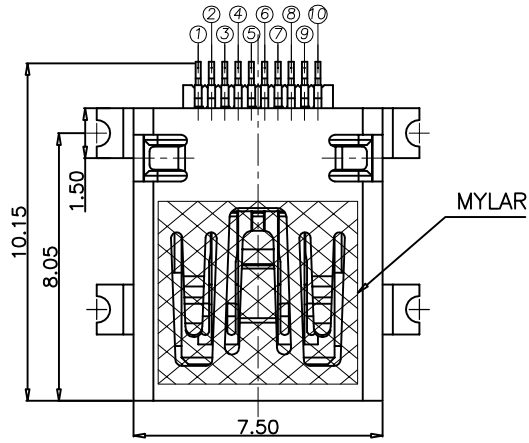

3D VIEW

NOTE:

1. ELECTRICAL CHARACTERISTICS
 - 1-1. CONTACT RESISTANCE: 80 milliohms MAX.
 - 1-2. INSULATION RESISTANCE: 1,000 Megohms MIN.
 - 1-3. DIELECTRIC WITHSTANDING VOLTAGE: 500V AC MIN FOR 1 MINUTE.
2. MECHANICAL CHARACTERISTICS
 - 2-1. RETENTION FORCE: MIN.100gf/PIN

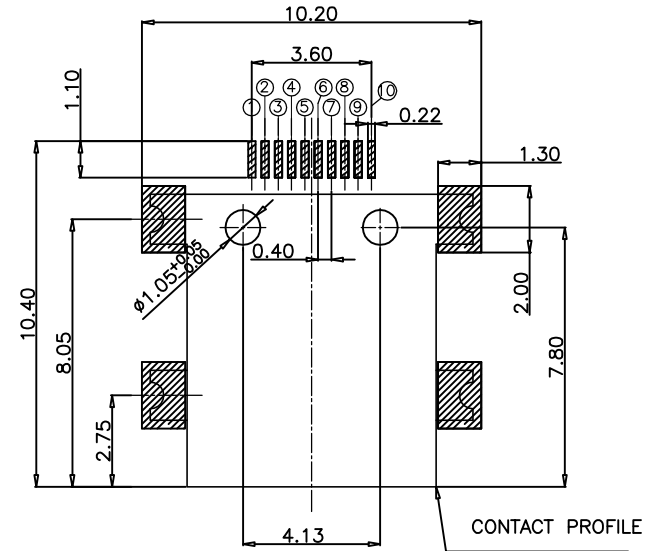
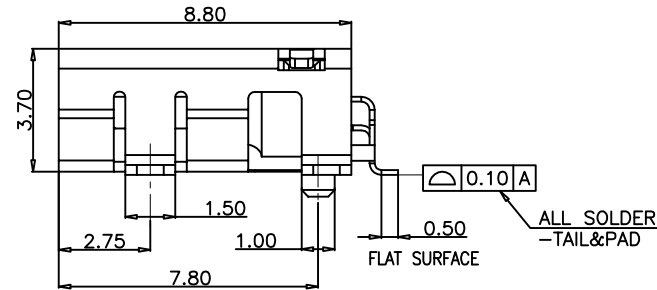
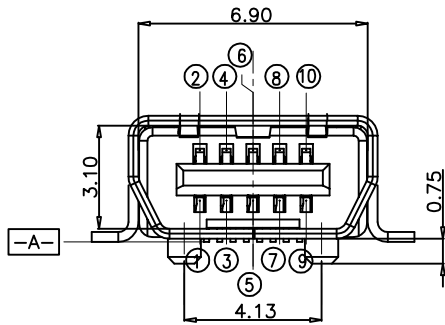

RECOMMENDED PCB LAYOUT(TOP VIEW)
GENERAL TOLERANCES: ±0.05

TABLE:

P/N.	TYPE
JYS-USB880-010	WITH POST
JYS-USB880-011	WITHOUT POST

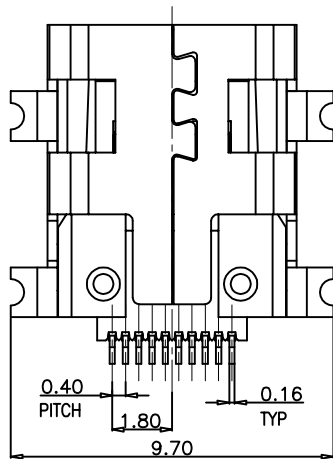

GENERAL TOLERANCE		DWG NO.	JYSA0709-001	APPD:	WIND	Scale	1:1
X.±0.45	x.±5°	Title	MINI USB 10P 母座 四脚全贴	CHKD:		UNIT	mm
.X±0.35	.x±2°			DR:			
.XX±0.25	.xx±1°	Part NO.	SEE TABLE	Date	2011/10/31		
.XXX±0.15	.xxx±0.5°						
SHEET	1/1			Shenzhen JYSCONN Electronics Co., LTD.			